

Product data overview

Vaculex[®] ML

Vacuum Lifting Systems



Vaculex[®] ML

Vaculex® ML

English

Introduction

Vaculex® ML - is a small, handy, really easy to operate vacuum lifter which can be manoeuvred with one hand. The lifter is appropriate for loads between 5 and 55 kg [11 and 121 lbs]. A number of electrical vacuum pumps are available. Another option is a pneumatic vacuum pump, that is very easy to install, since the pump is mounted on the top swivel.

One hand operated

Vaculex ML is a one hand operated vacuum lifter which is easily customized to adapt to most handling situations with loads weighing between 5 and 55 kg [11 and 121 lbs] .

Large possibilities

Vaculex ML offers large possibilities to choose between a range of different control handles, suction feet and other options to optimize the lifting system for your specific handling situation.

Easy to apply to your changing needs

Vaculex ML has a modular design which also makes it easy to reconfigure the lifting system if your needs are changing over time.

Benefit

- Operated with one hand
- User friendly and able to customize to fit customer specific needs
- For handling of loads between 5 kg and 55 kg [11 and 121 lbs]
- Ergonomic and Safe
 - o Reduces repetitive strain injuries and sick leave costs
 - o Reduces the risk of damage goods
- Increases productivity
- Reliable and with low service costs
- Modular system which can be reconfigured for new tasks over time
- Available as either Electric or Compressed Air powered
- Available with Vaculex ATOP for increased energy efficiency and maximum comfort
- Available with a wide range of different suction feet, vacuum pumps and other options

Identification

Product number consisting of a combination of the following set:

	Lift tube size	Pump Unit	
	06 = Ø 60mm [2.36 inch]	100 = 100 pneumatic ejector	
	08 = Ø 80mm [3.15 inch]	150 = 150 pneumatic ejector	
Lift Unit	10 = Ø 100mm [3.94 inch]	702 = 702 pump, noise hood	Three phase voltage
1 = ML	12 = Ø 120mm [4.72 inch]	802 = 802 pump, noise hood	[none] = No electricity (for ejectors)
			A = 50Hz / 200 - 220V Δ
			B = 50Hz / 220 - 240V Δ
			C = 50Hz / 380 - 420V Y
			D = 60Hz / 200 - 220V Δ
			E = 60Hz / 255 - 275V Δ
			F = 60Hz / 440 - 480V Y
			G = 60Hz / 380V Y

1
10
1
802
S
00
C
13

Number of suspension points on lift unit	Options	Multiple options
0 = No suspension point	0 = Standard lift unit	If "Options" is set to "S", then "Multiple options" will consist of several of the options, in alphabetical order.
1 = One suspension point	1 = Stainless steel	
2 = Two suspension (Always for pneumatic pumps)	3 = 3 meter lift tube [118 inch]	
	4 = 4 meter lift tube [157 inch]	
	6 = Protection Valve	
	8 = Partly stainless steel	
	D = Split Control Handle	
	G = Release Valve for Standard Handle	
	H = Release Valve for Extended Handle	
	K = Stainless filter unit	
	M = Electrically grounded lift unit	
	S = Special, for when multiple options are used	
	T = ATOP energy saving system	
	V = Protection Regulator	

Extended handle
00 = Standard handle
02 = 250mm extended handle [9.84 inch]
03 = 350mm extended handle [13.79 inch]
04 = 450mm extended handle [17.72 inch]
06 = 650mm extended handle [25.59 inch]
08 = 850mm extended handle [33.46 inch]
0A = Any Length up to 1200mm [47.24 inch]
2x* = 200mm [7.87 inch] + Xmm*
3x* = 300mm [11.81 inch] + Xmm*
4x* = 400mm [15.75 inch] + Xmm*
5x* = 500mm [19.69 inch] + Xmm*
7x* = 700mm [27.56 inch] + Xmm*
0B = Any Length up to 1200mm* [47.24 inch]
* = Two part extended handle with hinge.
Length of the second handle.
3 = 300 [11.81 inch], 5 = 500 [19.69 inch],
6 = 600 [23.62inch] or 7 = 700 [27.56 inch].

Example:

1 10 1 802 S 00 C 13 = ML lift unit in stainless steel, 3m [118 inch], 100mm [3.94 inch] tube with one suspension point, 802 pump with noise hood 380-420V 50Hz and a standard handle.

Vaculex® ML

English



Identification

Clarification of Options:

- 0 = Standard lift unit.
- 1 = Stainless steel - All metal parts in the lift unit are made from stainless steel grade 304.
- 3 = 3 meter lift tube - The length of the lift tube is 3m [118 inch].
- 4 = 4 meter lift tube - The length of the lift tube is 4m [157 inch].
- 6 = Protection Valve - The lifter is equipped with a mechanical protection valve (anti jump valve) that prevents the lifter from jumping up in high speed in the unlikely event of dropping the load. Should be used in combination with dead end tools or situations where there is a risk of dropping the load, but the suction foot is still covered by part of the lift object.
- 8 = Partly stainless steel - All metal parts in the control unit are made from stainless steel grade 304.
- D = Split Control Handle - The control handle is split in two parts. The vacuum hose is mounted above the tool and the control house is mounted somewhere on the tool. Both parts are connected by a flexible hose.
- G = Release Valve for Standard Handle - Release valve for standard handle. Recommend when you have high safety factor of the suction foot and needs extra help to release the object. This is also good when you need to release the object before its firmly put downed on the underlying surface. Eg. loading on to a moving conveyor belt.
- H = Release Valve for Extended Handle - Please see the explanation for release valve for standard handle. Recommended to always include this option together with an extended handle.
- K = Stainless filter unit - Filter unit in stainless steel grade 304.
- M = Electrically grounded lift unit - Grounded lift unit without cover sock.
- S = Special, for when multiple options are used.
- T = ATOP energy saving system - The system detects when the lifter has been inactive for x seconds and automatically turns the pump unit off. Supplied with remote control used to start the pump again.
- V = Protection Regulator - Protection regulator to set the maximum allowed vacuum level in the system. Eg. to insure that it's not possible to lift more than the maximum allowed load.

Lifting Capacity

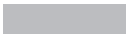
Find the best Lift Unit/Pump combination

Non porous Lifting object 
 Porous Lifting object 

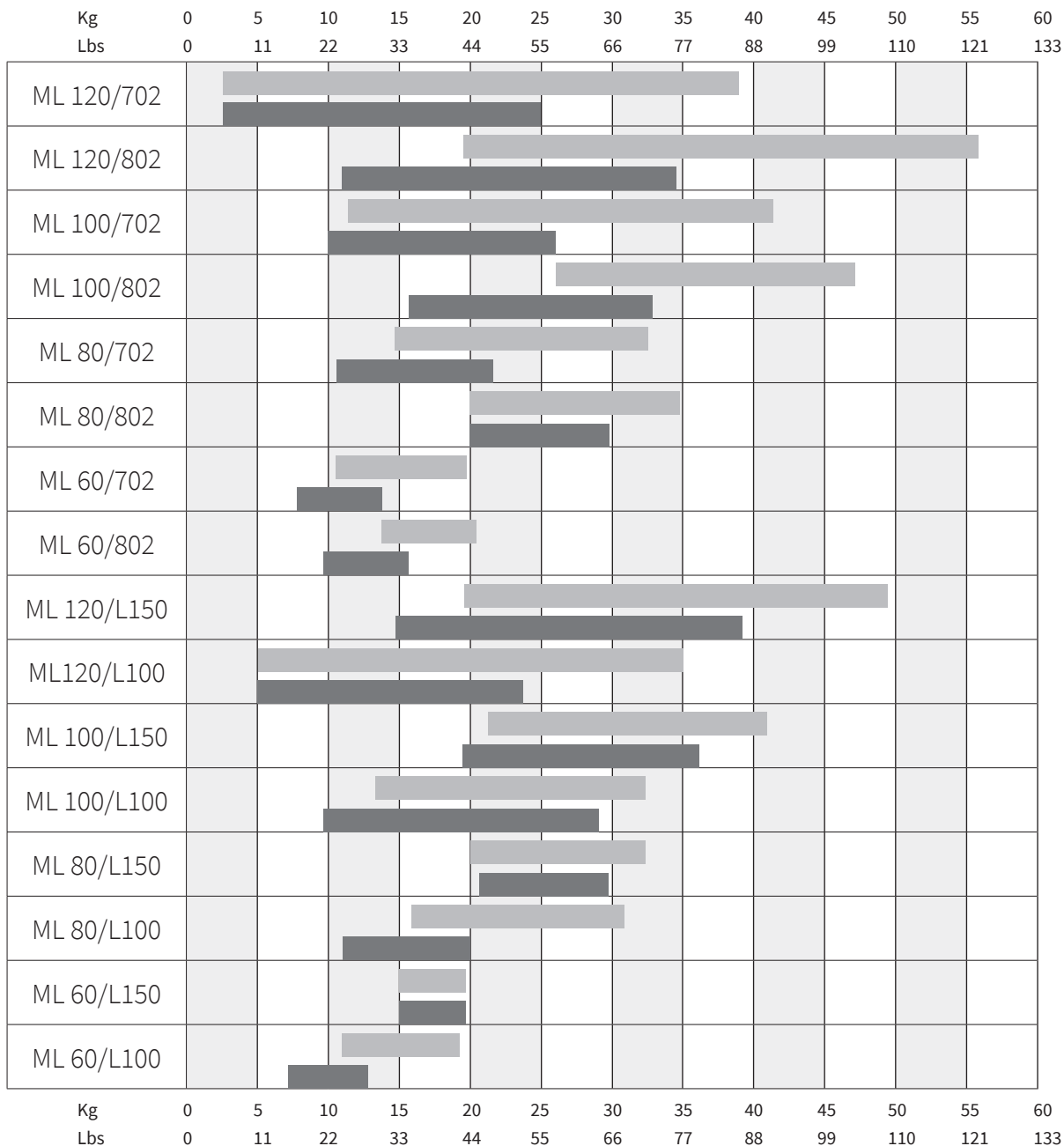

The bars show recommended “weight interval” in kg [lbs] (for the lifted objects) regarding actual Lift Unit/Pump combination. To the left of the bar it takes 2 seconds for the Lift Unit/Pump combination to evacuate and lift 1 meter [39.4 inch]. To the right it takes 4 seconds.

We have been using a rectangular suction foot during our tests, therefore you must consider the extra weight if you choose a heavier suction foot. Note! Try to choose as big Lift Tube as possible. This will give you a “softer” and smother Lift Unit.

Vaculex® ML

English

Drawing overview

Simplified drawings with key measurements.

Without suction foot or similar (with the possibility to choose suitable foot).

Dimension mm [in]

Model	LTD	LA	TD	CD
ML60	60 [2.36]	Max 2850 [112.2] Stroke: 1840 [72.4]	19 [0.75]	25 [0.98]
ML80	80 [3.15]	Max: 2850 [112.2] Stroke: 1840 [72.4]	19 [0.75]	25 [0.98]
ML100	100 [3.94]	Max: 2850 [112.2] Stroke: 1720 [67.7]	19 [0.75]	25 [0.98]
ML120	120 [4.72]	Max: 2850 [112.2] Stroke: 1750 [68.9]	19 [0.75]	25 [0.98]

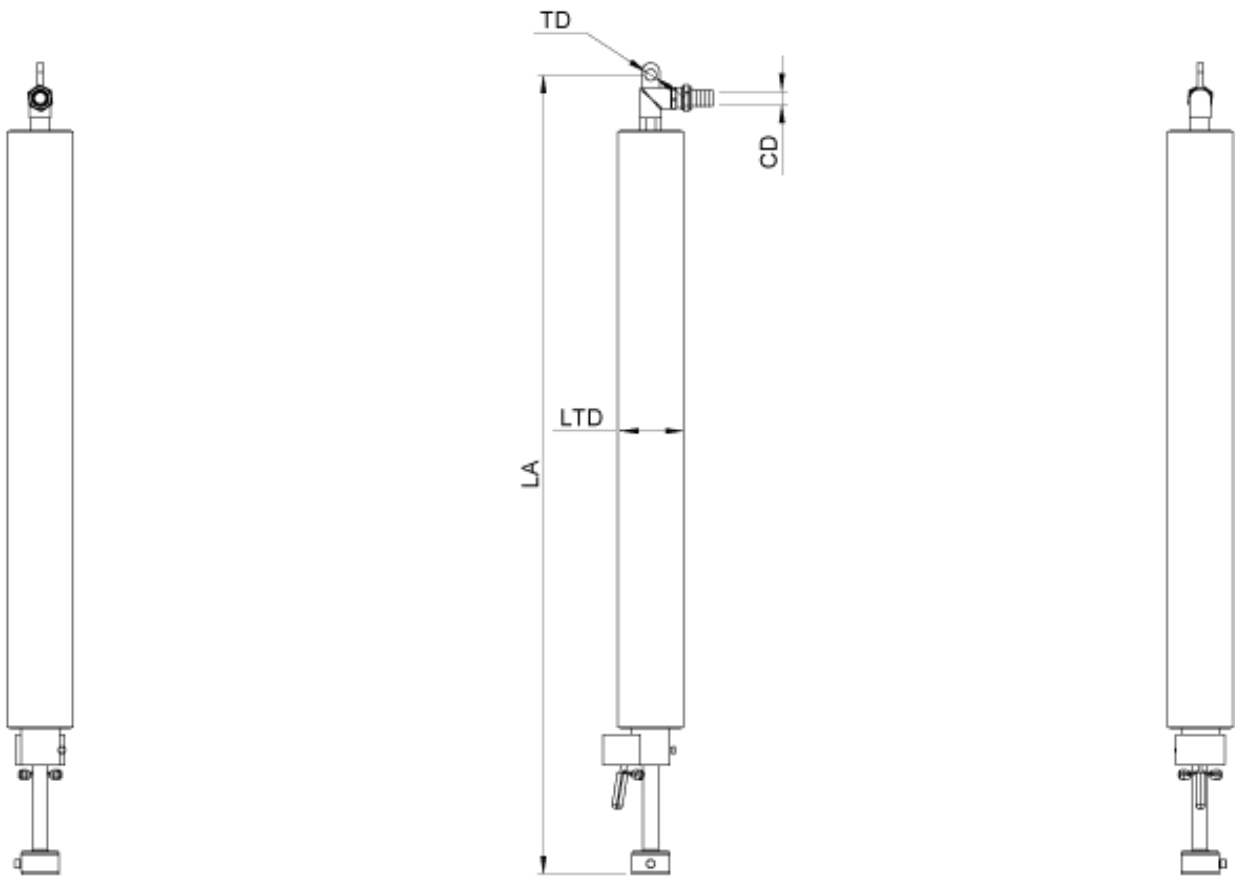

Vaculex® ML

Pump

These are the electrical and pneumatic pumps for the ML series.

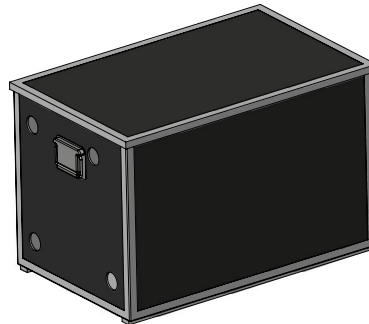

Pumpunit, electric	702		802	
Frequency (Hz)	50Hz	60Hz	50Hz	60Hz
Power (kW)	0.75	0.9	1.25	1.5
Voltage (V)	X*	Y*	X*	Y*
Weight (kg) [lbs]	61 [134.5]		69 [152]	
Dimensions LxWxH (mm) [inch]	815x515x540 [32x20.3x21.3]		815x515x540 [32x20.3x21.3]	
Sound level (dBA)	54	56	54	56

X = 50Hz, 3 - phase	Y = 60Hz, 3 - phase
200V Δ	220V Δ
230V Δ	265V Δ
350V Y	380-400V Y
400V Y	460V Y

Pumpunit, pneumatic	100	150
Air consumption (NI/min at 6 bar) [scfm at 87 psi]	420 [14.8]	630 [22.2]
Sound level (dBA)	60-65	60-65

Crane and Over Head system

Several types of Crane and Over Head system can be used with the Vaculex® ML.

These are the most common systems. More info in the separate datasheet for Cranes and Over Head systems.



Bridge Cranes



Slewing Jib Cranes

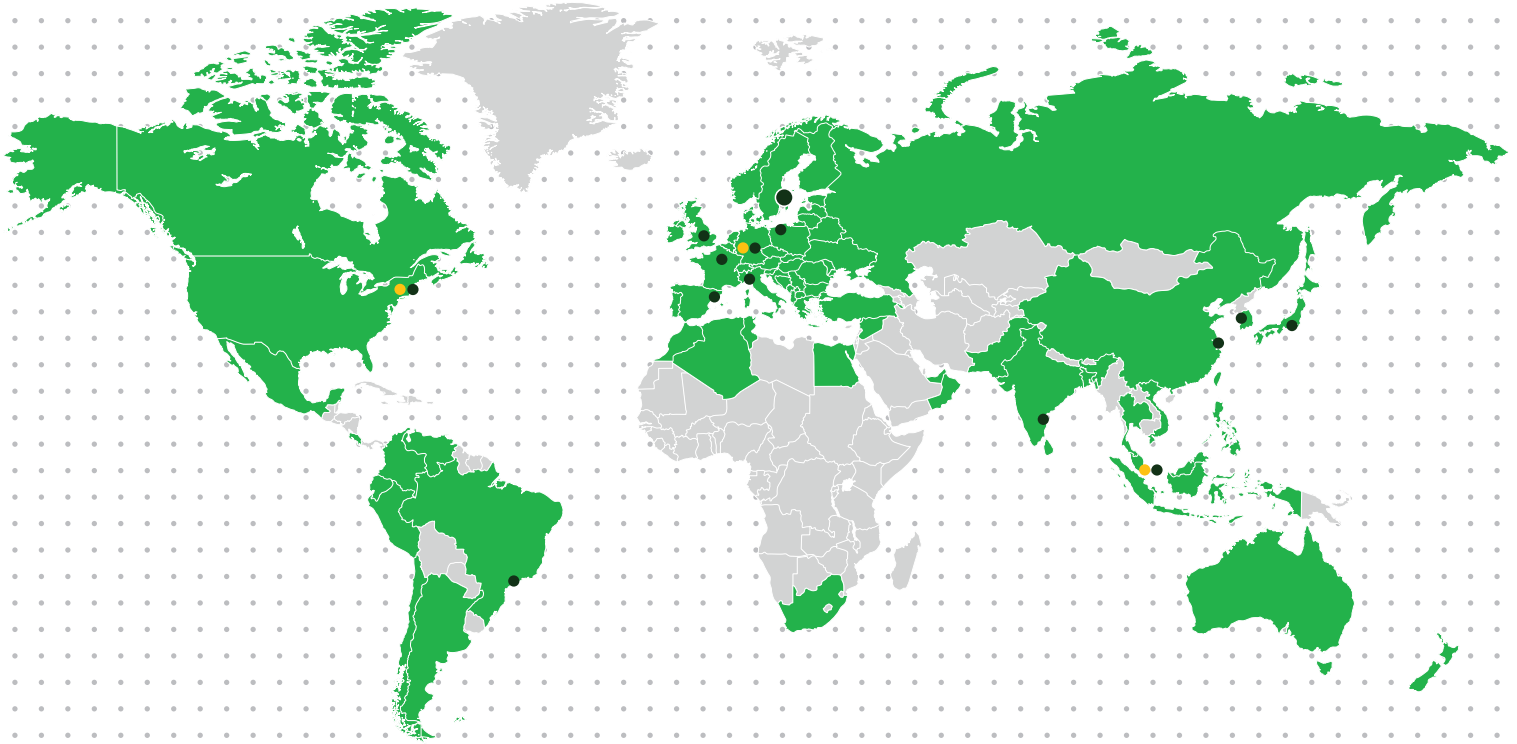

www.piab.com

BRAZIL – Sao Paulo
 Phone: +55 11 4492 9050
 Email: info-brasil@piab.com

CANADA – Hingham MA (US)
 Phone: +1 781 337 7309
 Email: info-usa@piab.com

CHINA – Shanghai
 Phone: +86 21 5237 6545
 Email: info-china@piab.com

FRANCE – Lagny sur Marne
 Phone: +33 1 6430 8267
 Email: info-france@piab.com

GERMANY – Butzbach
 Phone: +49 6033 7960-0
 Email: info-germany@piab.com

GERMANY – Schmallenberg
 Robotic gripping
 Phone: +49 (0) 29 72/962 17-11
 Email: info-germany@piab.com

MEXICO – Hingham MA (US)
 Phone: +1 781 337 7309
 Email: info-mxca@piab.com

INDIA – Chennai
 Phone: +91 9444 25 36 48
 Email: info-india@piab.com

ITALY – Torino
 Phone: +39 011 226 36 66
 Email: info-italy@piab.com

JAPAN – Tokyo
 Phone: +81 3 6662 8118
 Email: info-japan@piab.com

POLAND – Gdansk
 Phone: +48 58 785 08 50
 Email: info-poland@piab.com

SPAIN – Barcelona
 Phone: +34 93 6333876
 Email: info-spain@piab.com

SINGAPORE
 Phone: +65 6455 7006
 Email: info-singapore@piab.com

SOUTH KOREA – Dokok-Dong
 Phone: +82 2 3463 0751
 Email: info-korea@piab.com

SWEDEN – Stockholm (HQ)
 Phone: +46 8 630 25 00
 Email: info-sweden@piab.com

SWEDEN – Mölndal
 Ergonomic handling
 Phone: +46 31 67 01 00
 Email: info-sweden@piab.com

UNITED KINGDOM –
 Loughborough
 Phone: +44 1509 857 010
 Email: info-uk@piab.com

USA – Hingham (MA)
 Phone: +1 781 337 7309
 Email: info-usa@piab.com

USA – Xenia (OH)
 Robotic gripping
 Phone: +1 888 727 3628
 Email: info-usa@piab.com

USA – Charlotte (NC)
 Ergonomic handling
 Phone: +1 704 527 5052
 Email: info-usa@piab.com

Smart solutions for the automated world™

